

Satellite

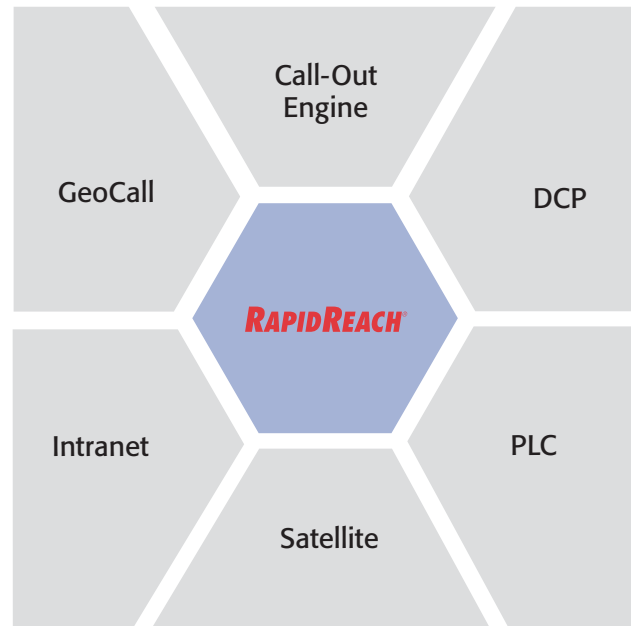

Enables several RapidReach systems to use the same communication resources



When there is a need for several distributed RapidReach systems one solution may be to implement these systems using shared communication equipment through the RapidReach Satellite option.

What is RapidReach Satellite?

In a large organisation different divisions of the organisation sometimes have a need for a dedicated system. The RapidReach Satellite option enables all these systems to share the same communication resources, avoiding duplication of equipment and communication lines. RapidReach Satellite is especially suitable when slow network performance makes it difficult to use one RapidReach networked system or when each system has individual requirements making it difficult to combine in one RapidReach system. The Satellite can be a stand alone (Standard) or a multi user network (Professional) system sharing communication resources.

RapidReach satellite
One complete RapidReach Pro system
and 3 RapidReach satellite systems

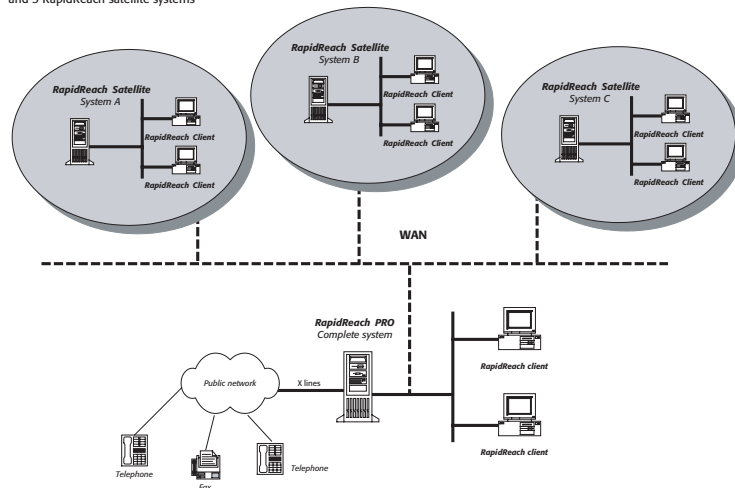

How does it work?

The RapidReach Satellite system is a distributed solution. Each satellite is self contained, sharing only centralised communication resources. Configuration and maintenance of the data is done separately in each satellite system. When a call-out or a scenario is activated the satellite server connects to the main RapidReach system, transfers part of the call-out information encrypted. The call-out is performed by the main RapidReach system and the Satellite system is updated about the progress. Only necessary information for the call-out is transferred excluding names and other information unnecessary for the call-out.

Compared to running the call-out directly on the main system everything behaves exactly the same, except for a slower start and monitoring. This delay is dependent on the communication performance between the satellite and the main system. The satellite can be connected to the main system via LAN, WAN, a dial-up connection or even through e-mail communications. One satellite system can even connect to several main systems to increase redundancy.

RapidReach Satellite features:

- RapidReach Satellite option enables systems to share the same communication resources avoiding duplication of equipment and communication lines.
- The satellite can be connected to the main system via LAN, WAN, a dial up connection or even through e-mail communications.
- The RapidReach Satellite system consists of a RapidReach database and a RapidReach Satellite server administering the users and the communication with the main RapidReach system.
- One satellite system can connect to several main systems to increase redundancy.
- The satellite can be a stand-alone (Standard) system or a multi user network (Professional) system.

